

OSFP-800G-2FR4-C

Arista Networks® Compatible TAA 800GBase-2xFR4 PAM4 OSFP Transceiver (SMF, 1310nm, 2km, 2xLC, DOM, CMIS 5.0)

Features:

- Supports Both Ethernet and InfiniBand NDR
- 2x400GAUI-4 C2M Electrical Interface
- 2x400GBASE-FR4 Optical Interface
- Support 850Gbps Aggregate Bit Rate
- InfiniBand NDR Electrical and Optical Interface
- Type 2 Housing with Dual LC Connector
- Class 1 Laser Certified
- I2C Management Interface Compliant to CMIS Rev5.0
- Hot-Pluggable OSFP Form Factor
- Operating Temperature: 0 to 70 Celsius
- RoHS Compliant and Lead-Free



Applications:

- 2x400GBase Ethernet

Product Description

This Arista Networks® compatible OSFP transceiver provides 800GBase-2xFR4 throughput up to 2km over single-mode fiber (SMF) PAM4 using a wavelength of 1310nm via a 2xLC connector. It can operate at temperatures between 0 and 70C. All of our transceivers are built to comply with Multi-Source Agreement (MSA) standards and are uniquely serialized and tested for data-traffic and application to ensure seamless network integration. Additional product features include Digital Optical Monitoring (DOM) support which allows access to real-time operating parameters. This transceiver is Trade Agreements Act (TAA) compliant. We stand behind the quality of our products and proudly offer a limited lifetime warranty.

ProLabs' transceivers are RoHS compliant and lead-free.

TAA refers to the Trade Agreements Act (19 U.S.C. & 2501-2581), which is intended to foster fair and open international trade. TAA requires that the U.S. Government may acquire only "U.S.-made or designated country end products.")



Absolute Maximum Ratings

Parameter	Symbol	Min.	Typ.	Max.	Unit	Notes
Power Supply Voltage	Vcc	-0.5		3.6	V	
Storage Temperature	Tstg	-40		85	°C	
Operating Case Temperature	Tc	0		70	°C	1
Relative Humidity (Non-Condensing)	RH	5		95	%	
Maximum Power Dissipation	PDISS			16.5	W	
Maximum Power Dissipation (Low-Power Mode)	PDLP			2	W	
Signaling Speed Per Lane	DRL		53.125		GBd	
Operating Distance		2		2000	m	

Electrical Characteristics

Parameter	Symbol	Min.	Typ.	Max.	Unit	Notes
Power Supply Voltage	Vcc	3.135	3.3	3.465	V	
Data Input Voltage Differential	IVdip-VdinI			1	V	
Control Input Voltage Differential	Vi	-0.3		Vcc+0.5	V	
Control Output Current	Io	-20		20	mA	
Instantaneous Peak Current at Hot Plug	Icc_IP			6600	mA	
Sustained Peak Current at Hot Plug	Icc_SP			5494.5	mA	
Control Input Voltage - High	VIH	Vcc*0.7		Vcc+0.3	V	
Control Input Voltage - Low	VIL	-0.3		Vcc*0.3	V	
2-Wire Serial Interface Clock Rate				400	kHz	
Power Supply Noise (1kHz to 1MHz Pk-Pk)				66	mVp-p	
Transmitter						
Differential Pk-Pk Input Voltage Tolerance (TP1a)		750			mV	
Pk-Pk AC Common-Mode Voltage Tolerance	Low-Frequency (VCMLF)			32	mV	
	Full-Band (VCMFB)			80		
Differential-Mode to Common-Mode Return Loss	RLcd		802.3ck 120G-2		dB	
Effective Return Loss	ERL	8.5			dB	
Differential Termination Mismatch				10	%	
Single-Ended Voltage Tolerance Range		-0.4		3.3	V	
DC Common-Mode Voltage Tolerance		-0.35		2.85	V	
Receiver						
Pk-Pk AC Common-Mode Voltage	Low-Frequency (VCMLF)			32	mV	
	Full-Band (VCMFB)			80		

Differential Pk-Pk Output Voltage	Short-Mode				600	mV	
	Long-Mode				845		
Eye Height	EH	15				mV	
Vertical Eye Closure	VEC				12	dB	
Common-Mode to Differential-Mode Return Loss	RLDc	802.3ck 120G-1				dB	
Effective Return Loss	ERL	8.5				dB	
Differential Termination Mismatch					10	%	
Transition Time		8.5				ps	
DC Common-Mode Voltage Tolerance		-0.35			2.85	V	
Low-Speed Control and Sense Signals							
Module Output SCL and SDA	VOL	0			0.4	V	
Module Input SCL and SDA	VIL	-0.3			Vcc*0.3	V	
	VIH	Vcc*0.7			Vcc+0.5	V	
InitMode, ResetL, and ModSelL	VIL	-0.3			0.8	V	
	VIH	2			Vcc+0.3	V	
IntL	VOL	0			0.4	V	
	VOH	Vcc-0.5			Vcc+0.3	V	

Optical Characteristics

Parameter	Symbol	Min.	Typ.	Max.	Unit	Notes
Transmitter						
Wavelength L0, L4	$\lambda_{C0}, \lambda_{C4}$	1264.5	1271	1277.5	nm	
Wavelength L1, L5	$\lambda_{C1}, \lambda_{C5}$	1284.5	1291	1297.5	nm	
Wavelength L2, L6	$\lambda_{C2}, \lambda_{C6}$	1304.5	1311	1317.5	nm	
Wavelength L3, L7	$\lambda_{C3}, \lambda_{C7}$	1324.5	1331	1337.5	nm	
Side-Mode Suppression Ratio	SMSR	30			dB	
Total Average Launch Power	AOPT			10.4	dBm	
Average Launch Power Per Lane	AOPL	-3.2		4.4	dBm	1
Outer Optical Modulation Amplitude (OMA _{outer}) Per Lane	TDECQ < 1.4dB	TOMA	-0.2		3.7	dBm
	1.4dB ≤ TDECQ ≤ 3.4dB		-1.6+TDECQ			
Difference in Launch Power Between Any Two Lanes (OMA _{outer})	AOPd			3.9	dB	
Transmitter and Dispersion Eye Closure for PAM4 (TDECQ) Per Lane	TDECQ			3.4	dB	
Transmitter Eye Closure for PAM4 (TECQ) Per Lane	TECQ			3.4	dB	
TDECQ – TECQ				2.5	dB	
Overshoot/Undershoot				22	%	

Transmitter Power Excursion					1.8	dBm	
Average Launch Power of Off Transmitter Per Lane		Toff			-16	dBm	
Extinction Ratio		ER	3.5			dB	
Transmitter Transition Time (Maximum)		Tr			17	ps	
RIN_{17.1}OMA (Maximum)		RIN			-136	dB/Hz	
Optical Return Loss Tolerance		ORL			17.1	dB	
Transmitter Reflectance		TR			-26	dB	2
Receiver							
Wavelength L0, L4		$\lambda_{C0}, \lambda_{C4}$	1264.5	1271	1277.5	nm	
Wavelength L1, L5		$\lambda_{C1}, \lambda_{C5}$	1284.5	1291	1297.5	nm	
Wavelength L2, L6		$\lambda_{C2}, \lambda_{C6}$	1304.5	1311	1317.5	nm	
Wavelength L3, L7		$\lambda_{C3}, \lambda_{C7}$	1324.5	1331	1337.5	nm	
Damage Threshold Per Lane		AOPD	5.4			dBm	
Average Receive Power Per Lane		AOPR	-7.2		4.4	dBm	
Receive Power (OMAouter) Per Lane		OMAR			3.7	dBm	
Difference in Receive Power Between Any Two Lanes (OMAouter) Maximum		AOPg			4.1	dB	
Receiver Reflectance		RR			-26	dB	
Receiver Sensitivity (OMAouter) Per Lane	TECQ<1.4dB	SOMA			-4.6	dBm	
	1.4dB≤TECQ≤3.4dB				-6+TECQ		
Stressed Receiver Sensitivity (OMAouter) Per Lane		SRS			-2.6	dBm	3
Stressed Eye Closure for PAM4 (SECQ) Per Lane Under Test				3.4		dB	
OMAouter of Each Aggressor Lane				1.4		dBm	

Notes:

1. Average launch power, per lane (minimum) is informative and not the principal indicator of signal strength.
2. Transmitter reflectance is defined looking into the transmitter.
3. Measured with conformance test signal at TP3 for the BER=2.4x10⁻⁴.

Pin Descriptions

Pin	Logic	Symbol	Name/Description	Notes
1		GND	Module Ground.	
2	CML-I	Tx2+	Transmitter Data Non-Inverted.	
3	CML-I	Tx2-	Transmitter Data Inverted.	
4		GND	Module Ground.	
5	CML-I	Tx4+	Transmitter Data Non-Inverted.	
6	CML-I	Tx4-	Transmitter Data Inverted.	
7		GND	Module Ground.	
8	CML-I	Tx6+	Transmitter Data Non-Inverted.	
9	CML-I	Tx6-	Transmitter Data Inverted.	
10		GND	Module Ground.	
11	CML-I	Tx8+	Transmitter Data Non-Inverted.	
12	CML-I	Tx8-	Transmitter Data Inverted.	
13		GND	Module Ground.	
14	LVCNOS-I/O	SCL	2-Wire Serial Interface Clock.	
15		Vcc	+3.3V Power.	
16		Vcc	+3.3V Power.	
17	Multi-Level	LPWn/PRSn	Low-Power Mode/Module Present.	
18		GND	Module Ground.	
19	CML-O	Rx7-	Receiver Data Inverted.	
20	CML-O	Rx7+	Receiver Data Non-Inverted.	
21		GND	Module Ground.	
22	CML-O	Rx5-	Receiver Data Inverted.	
23	CML-O	Rx5+	Receiver Data Non-Inverted.	
24		GND	Module Ground.	
25	CML-O	Rx3-	Receiver Data Inverted.	
26	CML-O	Rx3+	Receiver Data Non-Inverted.	
27		GND	Module Ground.	
28	CML-O	Rx1-	Receiver Data Inverted.	
29	CML-O	Rx1+	Receiver Data Non-Inverted.	
30		GND	Module Ground.	
31		GND	Module Ground.	
32	CML-O	Rx2+	Receiver Data Non-Inverted.	
33	CML-O	Rx2-	Receiver Data Inverted.	
34		GND	Module Ground.	
35	CML-O	Rx4+	Receiver Data Non-Inverted.	
36	CML-O	Rx4-	Receiver Data Inverted.	
37		GND	Module Ground.	
38	CML-O	Rx6+	Receiver Data Non-Inverted.	
39	CML-O	Rx6-	Receiver Data Inverted.	

40		GND	Module Ground.
41	CML-O	Rx8+	Receiver Data Non-Inverted.
42	CML-O	Rx8-	Receiver Data Inverted.
43		GND	Module Ground.
44	Multi-Level	INT/RSTn	Module Interrupt/Module Reset.
45		Vcc	+3.3V Power.
46		Vcc	+3.3V Power.
47	LVCNOS-I/O	SDA	2-Wire Serial Interface Data.
48		GND	Module Ground.
49	CML-I	Tx7-	Transmitter Data Inverted.
50	CML-I	Tx7+	Transmitter Data Non-Inverted.
51		GND	Module Ground.
52	CML-I	Tx5-	Transmitter Data Inverted.
53	CML-I	Tx5+	Transmitter Data Non-Inverted.
54		GND	Module Ground.
55	CML-I	Tx3-	Transmitter Data Inverted.
56	CML-I	Tx3+	Transmitter Data Non-Inverted.
57		GND	Module Ground.
58	CML-I	Tx1-	Transmitter Data Inverted.
59	CML-I	Tx1+	Transmitter Data Non-Inverted.
60		GND	Module Ground.

Electrical Pad Layout

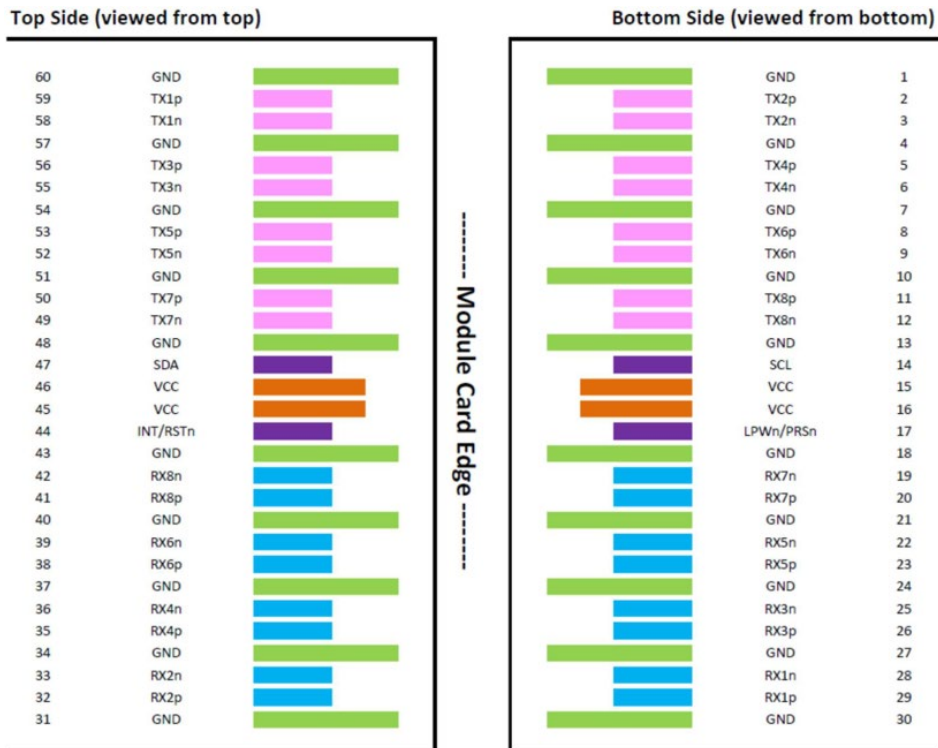

Recommended Host Board Schematic

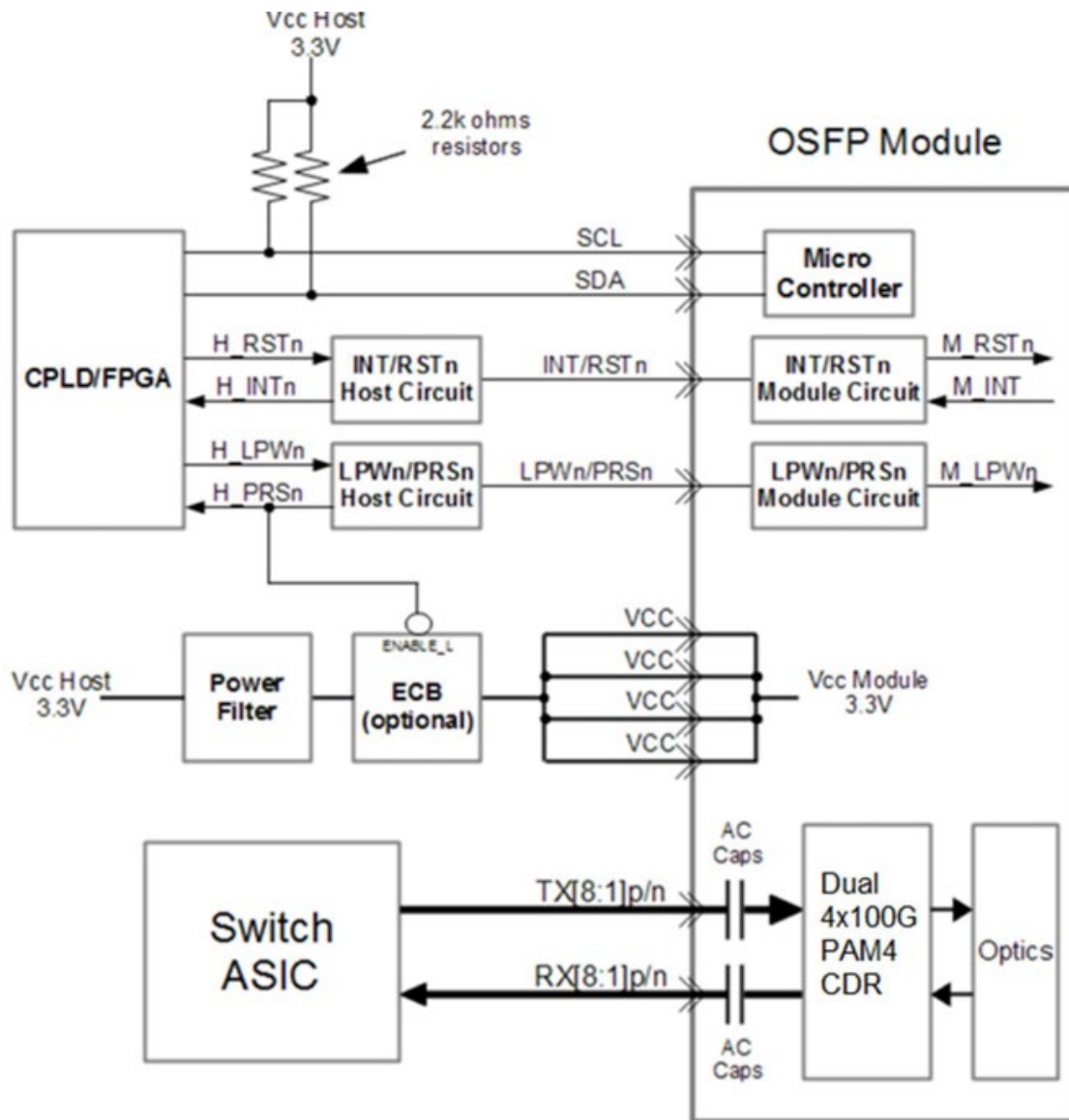

Mechanical Specifications

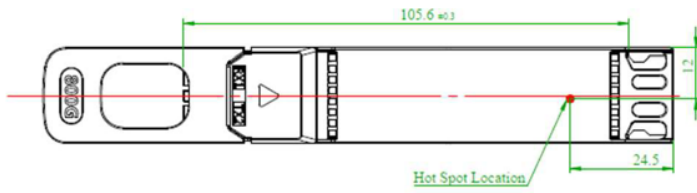
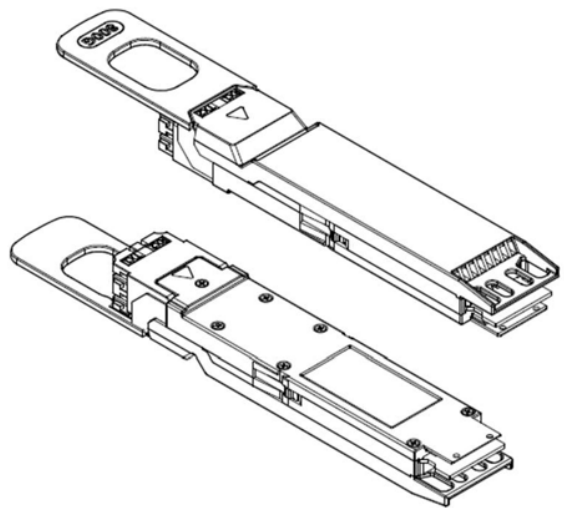
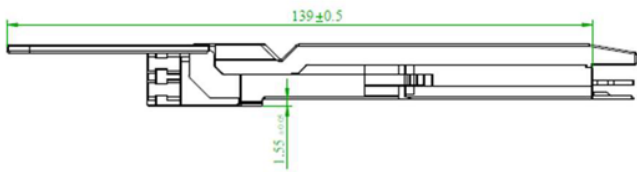
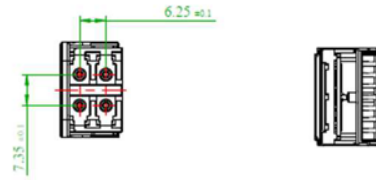
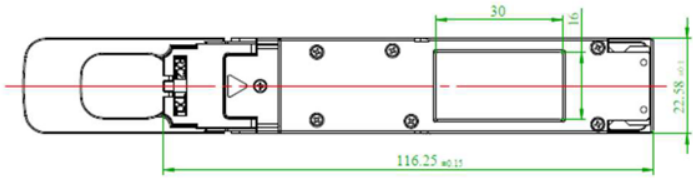
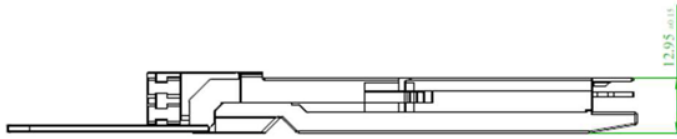

About ProLabs

Our extensive experience comes as standard. For over 20 years ProLabs has delivered optical connectivity solutions that give our customers freedom and choice through our ability to provide seamless interoperability. At the heart of our company is the ability to provide state-of-the-art optical transport and connectivity solutions that are compatible with more than 100 optical switching and transport platforms.

A Complete Portfolio of Network Solutions

ProLabs is focused on innovations in optical transport and connectivity. The combination of our knowledge of optics and networking equipment enables ProLabs to be your single source for optical transport and connectivity solutions from 100Mb to 1.6T while providing innovative solutions that increase network efficiency. We provide the optical connectivity expertise that is compatible with and enhances your switching and transport equipment.

The Trusted Partner

Customer service is our number one value. ProLabs has invested in people, labs and manufacturing capacity to ensure compatible products, and immediate answers to your questions. With Engineering and Manufacturing offices in the U.K. and U.S. augmented by field offices throughout the U.S., U.K. and Asia, ProLabs is able to be our customers best advocate 24 hours a day.



Contact Information

ProLabs US

Email: sales@prolabs.com

Telephone: 952-852-0252

ProLabs UK

Email: salessupport@prolabs.com

Telephone: +44 1285 719 600