

MMS4X00-NS-C

Mellanox® MMS4X00-NS Compatible TAA 800GBase-DR8 PAM4 OSFP Transceiver (SMF, 1310nm, 100m, 2xMPO, DOM, CMIS 5.0)

Features:

- OSFP MSA Compliant
- 8x100G PAM4/8x50G PAM4 data rates
- Supports both Ethernet and InfiniBand NDR
- Compliant with IEEE 802.3cu-2021: 8x100GBASE-DR optical interface
- Compliant with IEEE 802.3ck-2022: 8x100GAUI-1 C2M electrical interface
- EML transmitter and PIN PD receiver
- Cooled 1310 EML Laser
- Class 1 Laser
- Operating Temperature: 0 to 70 Celsius
- RoHS Compliant and Lead-Free
- RoHS Compliant and Lead-Free

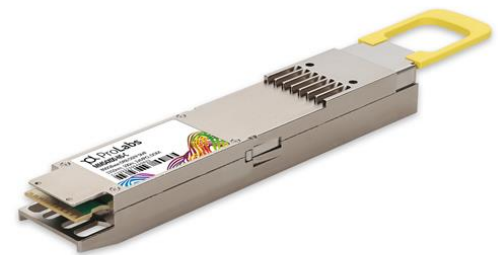

Applications:

- 2x400GBase Ethernet

Product Description

This Mellanox® MMS4X00-NS compatible OSFP transceiver provides 800GBase-DR8 throughput up to 100m over single-mode fiber (SMF) PAM4 using a wavelength of 1310nm via a 2xMPO connector. It can operate at temperatures between 0 and 70C. Our transceiver is built to meet or exceed OEM specifications and is guaranteed to be 100% compatible with Mellanox®. It has been programmed, uniquely serialized, and tested for data-traffic and application to ensure that it will initialize and perform identically. All of our transceivers comply with Multi-Source Agreement (MSA) standards to provide seamless network integration. Additional product features include Digital Optical Monitoring (DOM) support which allows access to real-time operating parameters. This transceiver is Trade Agreements Act (TAA) compliant. We stand behind the quality of our products and proudly offer a limited lifetime warranty.

ProLabs' transceivers are RoHS compliant and lead-free.

TAA refers to the Trade Agreements Act (19 U.S.C. & 2501-2581), which is intended to foster fair and open international trade. TAA requires that the U.S. Government may acquire only "U.S.-made or designated country end products.")



Absolute Maximum Ratings

Parameter	Symbol	Min.	Typ.	Max.	Unit	Notes
Power Supply Voltage	V _{CC}	-0.5		3.6	V	
Storage Temperature	T _{stg}	-40		85	°C	
Operating Case Temperature	T _c	0		70	°C	
Relative Humidity (Non-Condensing)	RH	15		85	%	
Data Rate			106.25		Gbps	
			53.125		Gbps	
Modulation Format			PAM4			

Electrical Characteristics

Parameter	Symbol	Min.	Typ.	Max.	Unit	Notes
Power Supply Voltage	V _{CC}	3.13	3.3	3.47	V	
Module Supply Current	I _{CC}			5.1	A	
Power Dissipation	P _{DISS}			16	W	
Transmitter						
Input Differential Impedance	Z _{IN}	90	100	110	Ω	
Differential Data Input Swing	V _{IN,pp}			900	mVp-p	
DC Common-Mode Input Voltage		-350		2850	mV	
Receiver						
Differential Data Output Swing	V _{OUT}			900	mV	
Output Differential Impedance	Z _{OUT}	90	100	110	Ω	1
Dual Function Signals						
INT/RSTn	V _{INT/RSTn1}	0.000	0.000	1.000	V	2
	V _{INT/RSTn2}	0.000	0.000	1.000	V	3
	V _{INT/RSTn3}	1.500	1.900	2.250	V	4
	V _{INT/RSTn4}	2.750	3.000	3.465	V	5
LPWn/PRSn	V _{LPWn/PRSn_1}	0.000	0.950	1.100	V	6
	V _{LPWn/PRSn_2}	1.400	1.700	2.250	V	7
	V _{LPWn/PRSn_3}	2.750	3.300	3.465	V	8

Notes:

1. Internally AC coupled but requires an external 100Ω differential load termination.
2. INT/RSTn voltage for no module.
3. INT/RSTn voltage for module installed, H_RSTn=Low.
4. INT/RSTn voltage for module installed, H_RSTn=High, M_INT=Low.
5. INT/RSTn voltage for module installed, H_RSTn=High, M_INT=High.

6. LPWn/PRSn for module installed, H_LPWn=Low.
7. LPWn/PRSn for module installed, H_LPWn=High.
8. LPWn/PRSn for no module.

Optical Characteristics

Parameter	Symbol	Min.	Typ.	Max.	Unit	Notes
Transmitter						
Average Launch Per Lane	Po(100G)	-2.9		4	dBm	1
	Po(50G)	-5.1		3	dBm	1
Outer Optical Modulation Amplitude Per Lane	Poma(100G)	-0.8		4.2	dBm	1
	Poma(50G)	-3		2.8	dBm	1
Extinction Ratio	ER	3.5			dB	2,3
Lane Wavelengths	λ	1304.5	1311	1317.5	nm	
Side-Mode Suppression Ratio	SMSR	30			dB	
Transmitter and Dispersion Penalty Eye Closure for 100Gbps PAM4 Per Lane	TDECQ1			3.4	dB	2
Transmitter and Dispersion Penalty Eye Closure for 50Gbps PAM4 Per Lane	TDECQ2			3.2	dB	3
Launch Power in OMAouter Minus TDECQ for 100Gbps PAM4 Per Lane	OMA-TDECQ	-2.2			dBm	2
Launch Power in OMAouter Minus TDECQ for 50Gbps PAM4 Per Lane	OMA-TDECQ	-4.4			dBm	3
Average Launch Power of Off Transmitter	Poff			-15	dBm	
Optical Return Loss Tolerance	ORLT			21.4	dB	
Transmitter Reflectance				-26	dB	
Receiver (10G)						
Lane Wavelengths		1304.5	1311	1317.5	nm	
100G Receiver Sensitivity (OMA)				-3.9	dBm	4
50G Receiver Sensitivity (OMA)				-6.1	dBm	5
Receiver Overload Per Lane (Pavg)		4			dBm	
Damage Threshold Per Lane		5			dBm	
Receive Power Per Lane (OMAouter)				4.2	dBm	
Receiver Reflectance				-26	dB	
LOS De-Assert				-10	dBm	
LOS Assert		-16			dBm	
LOS Hysteresis		0.5			dB	

Notes:

1. Class 1 Laser Safety per FDA/CDRH and EN (IEC) 60825 regulations.
2. Measured with SSPRQ test pattern, @106.25Gbps PAM4.
3. Measured with SSPRQ test pattern, @53.125Gbps PAM4.

4. Measured with PRBS31Q test pattern, @53.125GBd, PAM4, and BER<2.4E⁻⁴.
5. Measured with PRBS31Q test pattern, @26.5625GBd, PAM4, and BER<2.4E⁻⁴.

Pin Descriptions

Pin	Symbol	Name/Description	Logic	Plug Sequence	Direction	Notes
1	GND	Module Ground.		1		
2	Tx2+	Transmitter Data Non-Inverted.	CML-I	3	Input from Host	
3	Tx2-	Transmitter Data Inverted.	CML-I	3	Input from Host	
4	GND	Module Ground.		1		
5	Tx4+	Transmitter Data Non-Inverted.	CML-I	3	Input from Host	
6	Tx4-	Transmitter Data Inverted.	CML-I	3	Input from Host	
7	GND	Module Ground.		1		
8	Tx6+	Transmitter Data Non-Inverted.	CML-I	3	Input from Host	
9	Tx6-	Transmitter Data Inverted.	CML-I	3	Input from Host	
10	GND	Module Ground.		1		
11	Tx8+	Transmitter Data Non-Inverted.	CML-I	3	Input from Host	
12	Tx8-	Transmitter Data Inverted.	CML-I	3	Input from Host	
13	GND	Module Ground.		1		
14	SCL	2-Wire Serial Interface Clock.	LVC MOS-I/O	3	Bi-Directional	1
15	Vcc	+3.3V Power.		2	Power from Host	
16	Vcc	+3.3V Power.		2	Power from Host	
17	LPWn/PRSn	Low-Power Mode/Module Present.	Multi-Level	3	Bi-Directional	2
18	GND	Module Ground.		1		
19	Rx7-	Receiver Data Inverted.	CML-O	3	Output to Host	
20	Rx7+	Receiver Data Non-Inverted.	CML-O	3	Output to Host	
21	GND	Module Ground.		1		
22	Rx5-	Receiver Data Inverted.	CML-O	3	Output to Host	
23	Rx5+	Receiver Data Non-Inverted.	CML-O	3	Output to Host	
24	GND	Module Ground.		1		
25	Rx3-	Receiver Data Inverted.	CML-O	3	Output to Host	
26	Rx3+	Receiver Data Non-Inverted.	CML-O	3	Output to Host	
27	GND	Module Ground.		1		
28	Rx1-	Receiver Data Inverted.	CML-O	3	Output to Host	
29	Rx1+	Receiver Data Non-Inverted.	CML-O	3	Output to Host	
30	GND	Module Ground.		1		
31	GND	Module Ground.		1		
32	Rx2+	Receiver Data Non-Inverted.	CML-O	3	Output to Host	

33	Rx2-	Receiver Data Inverted.	CML-O	3	Output to Host	
34	GND	Module Ground.		1		
35	Rx4+	Receiver Data Non-Inverted.	CML-O	3	Output to Host	
36	Rx4-	Receiver Data Inverted.	CML-O	3	Output to Host	
37	GND	Module Ground.		1		
38	Rx6+	Receiver Data Non-Inverted.	CML-O	3	Output to Host	
39	Rx6-	Receiver Data Inverted.	CML-O	3	Output to Host	
40	GND	Module Ground.		1		
41	Rx8+	Receiver Data Non-Inverted.	CML-O	3	Output to Host	
42	Rx8-	Receiver Data Inverted.	CML-O	3	Output to Host	
43	GND	Module Ground.		1		
44	INT/RSTn	Module Interrupt/Module Reset.	Multi-Level	3	Bi-Directional	2
45	Vcc	+3.3V Power.		2	Power from Host	
46	Vcc	+3.3V Power.		2	Power from Host	
47	SDA	2-Wire Serial Interface Data.	LVC MOS-I/O	3	Bi-Directional	1
48	GND	Module Ground.		1		
49	Tx7-	Transmitter Data Inverted.	CML-I	3	Input from Host	
50	Tx7+	Transmitter Data Non-Inverted.	CML-I	3	Input from Host	
51	GND	Module Ground.		1		
52	Tx5-	Transmitter Data Inverted.	CML-I	3	Input from Host	
53	Tx5+	Transmitter Data Non-Inverted.	CML-I	3	Input from Host	
54	GND	Module Ground.		1		
55	Tx3-	Transmitter Data Inverted.	CML-I	3	Input from Host	
56	Tx3+	Transmitter Data Non-Inverted.	CML-I	3	Input from Host	
57	GND	Module Ground.		1		
58	Tx1-	Transmitter Data Inverted.	CML-I	3	Input from Host	
59	Tx1+	Transmitter Data Non-Inverted.	CML-I	3	Input from Host	
60	GND	Module Ground.		1		

Notes:

1. Open-drain with pull-up resistor on the host.
2. See pin assignments below for the required circuit.

Electrical Pin-Out Details

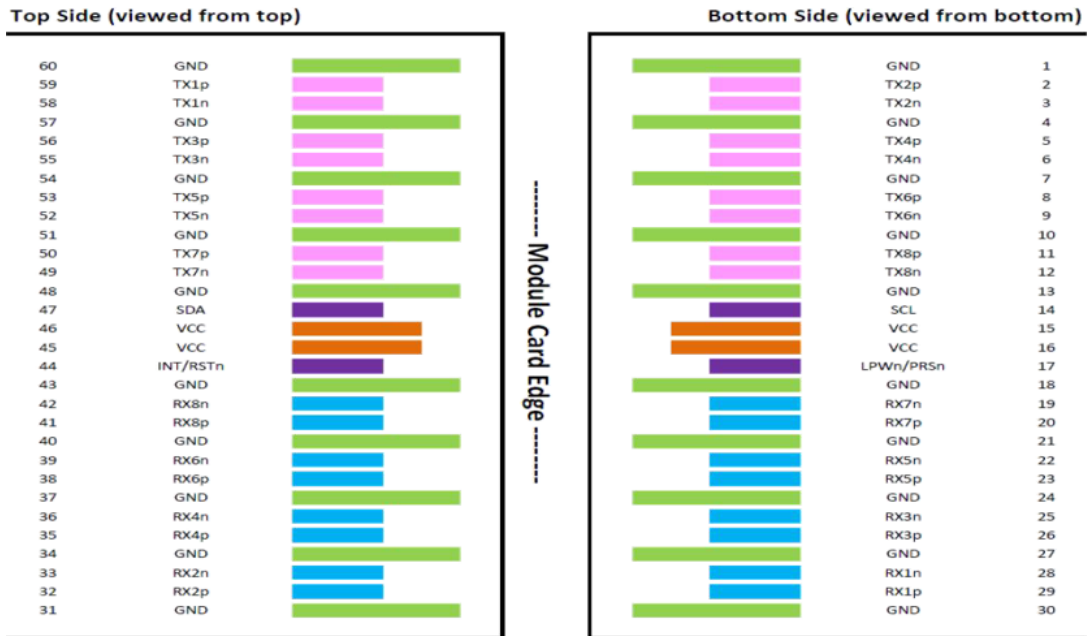

Recommended Host Board Power Supply Filter Network

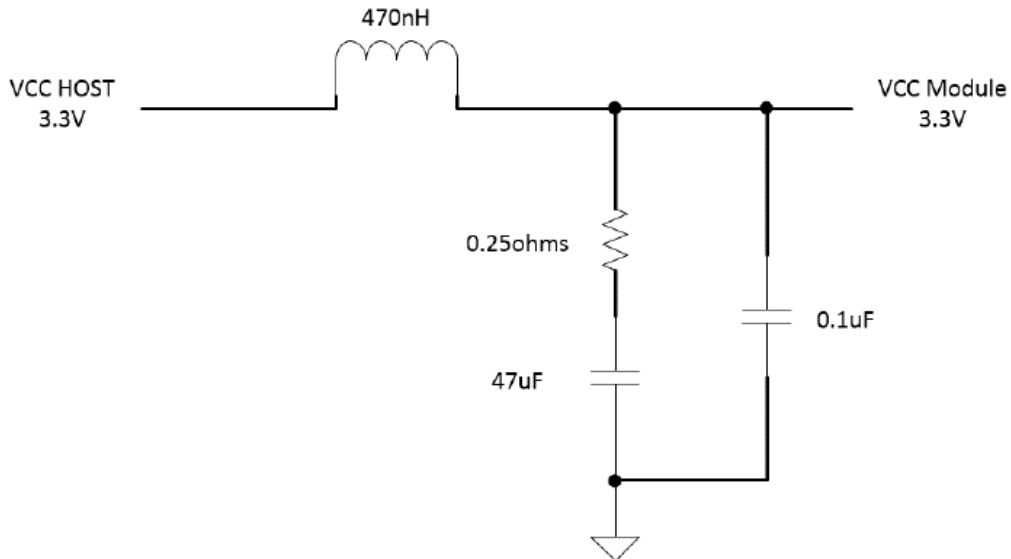

Block Diagram

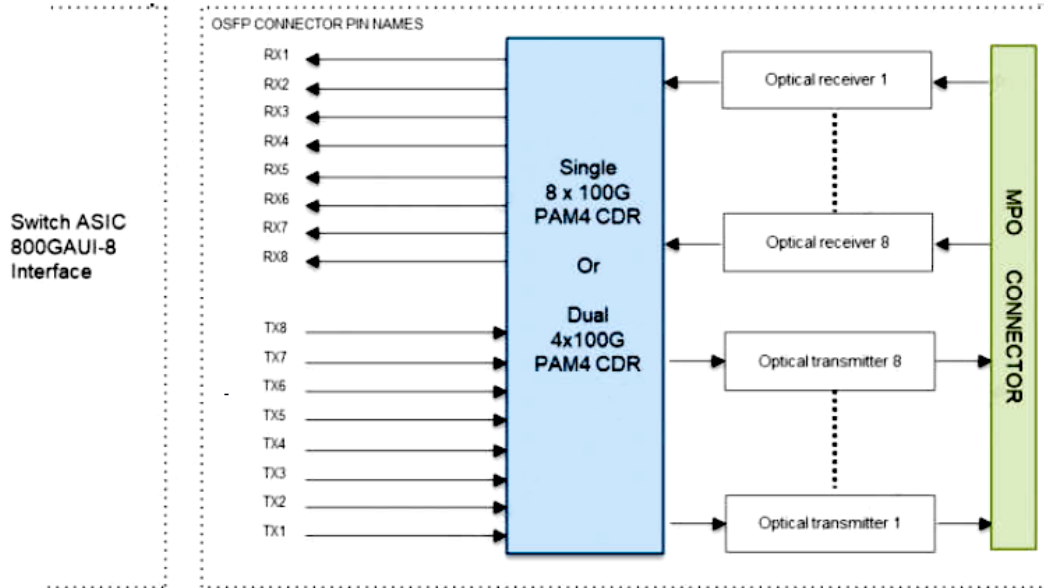

Recommended Application Interface Block Diagram

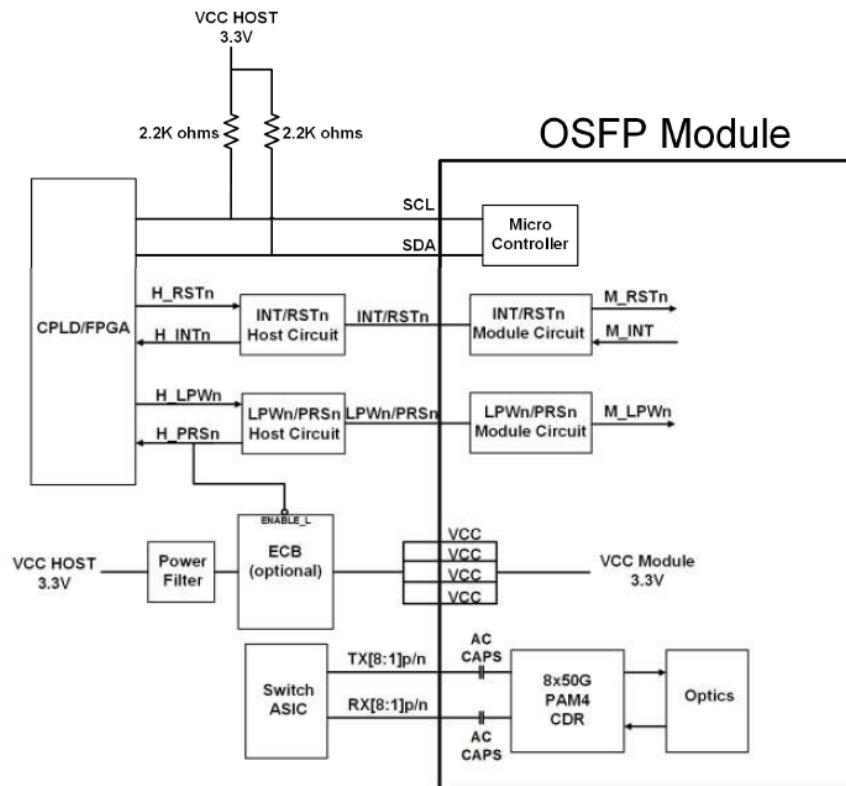

Mechanical Specifications

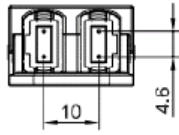

Unit:mm

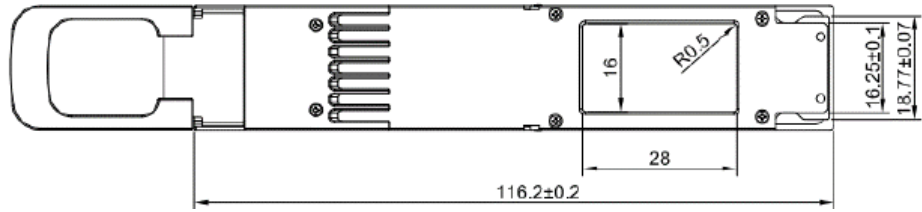
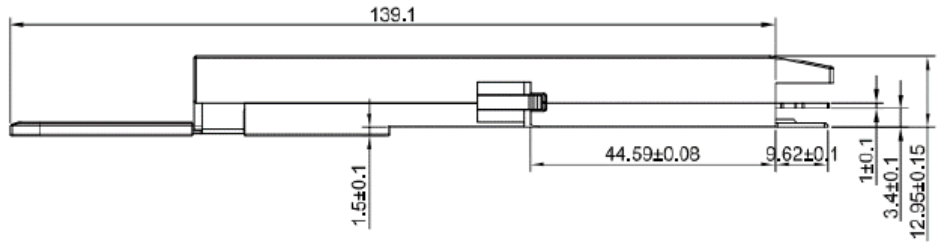
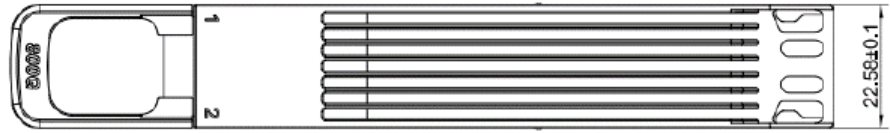

About ProLabs

Our extensive experience comes as standard. For over 20 years ProLabs has delivered optical connectivity solutions that give our customers freedom and choice through our ability to provide seamless interoperability. At the heart of our company is the ability to provide state-of-the-art optical transport and connectivity solutions that are compatible with more than 100 optical switching and transport platforms.

A Complete Portfolio of Network Solutions

ProLabs is focused on innovations in optical transport and connectivity. The combination of our knowledge of optics and networking equipment enables ProLabs to be your single source for optical transport and connectivity solutions from 100Mb to 1.6T while providing innovative solutions that increase network efficiency. We provide the optical connectivity expertise that is compatible with and enhances your switching and transport equipment.

The Trusted Partner

Customer service is our number one value. ProLabs has invested in people, labs and manufacturing capacity to ensure compatible products, and immediate answers to your questions. With Engineering and Manufacturing offices in the U.K. and U.S. augmented by field offices throughout the U.S., U.K. and Asia, ProLabs is able to be our customers best advocate 24 hours a day.



Contact Information

ProLabs US

Email: sales@prolabs.com

Telephone: 952-852-0252

ProLabs UK

Email: salessupport@prolabs.com

Telephone: +44 1285 719 600