

MMA4Z00-NS-C

Mellanox® MMA4Z00-NS Compatible TAA 800GBase-2xSR4 PAM4 OSFP Transceiver (MMF, 850nm, 50m, 2xMPO, DOM, CMIS 5.0)

Features:

- OSFP MSA Compliant
- Supports 850Gbps
- 8x53.125Gb/s (PAM4) Electrical Interface
- Dual MPO-12 Connector APC
- Commercial Temperature: 0 to 70 Celsius
- VCSEL Transmitter
- PIN and TIA Array on the Receiver Side
- RoHS Compliant and Lead-Free



Applications:

- 2x400GBase Ethernet
- 8x100GBase Ethernet

Product Description

This Mellanox® MMA4Z00-NS compatible OSFP transceiver provides 800GBase-2xSR4 throughput up to 50m over multi-mode fiber (MMF) PAM4 using a wavelength of 850nm via a 2xMPO connector. It can operate at temperatures between 0 and 70C. Our transceiver is built to meet or exceed OEM specifications and is guaranteed to be 100% compatible with Mellanox®. It has been programmed, uniquely serialized, and tested for data-traffic and application to ensure that it will initialize and perform identically. All of our transceivers comply with Multi-Source Agreement (MSA) standards to provide seamless network integration. Additional product features include Digital Optical Monitoring (DOM) support which allows access to real-time operating parameters. This transceiver is Trade Agreements Act (TAA) compliant. We stand behind the quality of our products and proudly offer a limited lifetime warranty.

ProLabs' transceivers are RoHS compliant and lead-free.

TAA refers to the Trade Agreements Act (19 U.S.C. & 2501-2581), which is intended to foster fair and open international trade. TAA requires that the U.S. Government may acquire only "U.S.-made or designated country end products."



Absolute Maximum Ratings

Parameter	Symbol	Min.	Typ.	Max.	Unit	Notes
Storage Temperature	T _{stg}	-40		85	°C	
Operating Case Temperature	T _c	0		70	°C	1
Power Supply Voltage	V _{cc}	-0.5		3.6	V	
Relative Humidity (Non-Condensing)	RH	5		85	%	
Data Input Voltage Differential	V _{DIP-V_{DIN}}			1	V	
Control Input Voltage	V _i	-0.3		V _{cc} +0.5	V	
Control Output Current	I _o	-20		20	mA	
Signaling Speed Per Lane	DRL		53.125		GBd	
Operating Distance		2		50	m	1
Data Rate	DR		850		Gbps	

Notes:

- 0.5m to 30m for OM3, 0.5m to 50m for OM4 and OM5, with FEC.

Electrical Characteristics

Parameter	Symbol	Min.	Typ.	Max.	Unit	Notes
Power Supply Voltage	V _{cc}	3.135	3.3	3.465	V	
Instantaneous Peak Current at Hot Plug	I _{CC_IP}			6400	mA	
Sustained Peak Current at Hot Plug	I _{CC_SP}			5328	mA	
Maximum Power Dissipation	PD			16	W	
Maximum Power Dissipation (Low-Power Mode)	PD _{LP}			2	W	
Control Input Voltage - High	V _{IH}	V _{cc} *0.7		V _{cc} +0.3	V	
Control Input Voltage - Low	V _{IL}	-0.3		V _{cc} *0.3	V	
2-Wire Serial Interface Clock Rate				400	kHz	
Power Supply Noise (1kHz to 1MHz, Pk-Pk)				66	mVp-p	
Transmitter (Module Input, TP1)						
Differential Pk-Pk Input Voltage Tolerance		750			mV	
Pk-Pk AC Common-Mode Voltage Tolerance	Low-Frequency (VCM _{LF})	32			mV	
	Full-Band (VCM _{FB})	80			mV	
Differential-Mode to Common-Mode Return Loss	RL _{cd}	802.3ck 120G-2			dB	
Effective Return Loss	ERL	8.5			dB	
Differential Termination Mismatch				10	%	
Single-Ended Voltage Tolerance Range		-0.4		3.3	V	
DC Common-Mode Voltage Tolerance		-0.35		2.85	V	
Receiver (Module Output, TP4)						

Pk-Pk AC Common-Mode Voltage	Low-Frequency ($V_{CM_{LF}}$)				32	mV	
	Full-Band ($V_{CM_{FB}}$)				80	mV	
Differential Pk-Pk Output Voltage	Short-Mode				600	mV	
	Long-Mode				845	mV	
Eye Height	EH	15				mV	
Vertical Eye Closure	VEC				12	dB	
Common-Mode to Differential-Mode Return Loss	RLDc	802.3ck 120G-1				dB	
Effective Return Loss	ERL	8.5				dB	
Differential Termination Mismatch					10	%	
Transition Time		8.5				ps	
DC Common-Mode Voltage Tolerance		-0.35			2.85	V	

Electrical Low-Speed Control and Sense Signal Specifications

Parameter	Symbol	Min.	Max.	Unit	Notes
Module Output SCL and SDA	VOL	0	0.4	V	
Module Input SCL and SDA	VIL	-0.3	$V_{CC} \cdot 0.3$	V	
	VIH	$V_{CC} \cdot 0.7$	$V_{CC} + 0.5$	V	
InitMode, ResetL, and ModSelL	VIL	-0.3	0.8	V	
	VIH	2	$V_{CC} + 0.3$	V	
IntL	VOL	0	0.4	V	
	VOH	$V_{CC} - 0.5$	$V_{CC} + 0.3$	V	

Optical Characteristics

Parameter	Symbol	Min.	Typ.	Max.	Unit	Notes
Transmitter						
Signaling Rate Per Lane (Range)		53.125 ± 100ppm			GBd	
Wavelength	λ_C	844		860	nm	
RMS Spectral Width	RMS			0.65	dB	1
Average Launch Power Per Lane	AOP_L	-4.6		4.0	dBm	
Outer Optical Modulation Amplitude (OMA _{outer}) Per Lane	(TECQ, TDECQ) ≤ 1.8dB	OMA _{outer}	-2.6		3.5	dBm
	1.8 < (TECQ, TDECQ) ≤ 4.4dB		-4.4 + Max. (TECQ, TDECQ)			
Transmitter and Dispersion Eye Closure for PAM4 (TDECQ) Per Lane	TDECQ			4.4	dB	
Transmitter Eye Closure for PAM4 (TECQ) Per Lane	TECQ			4.4	dB	
Over/Under-Shoot				29	%	
Transmitter Power Excursion Per Lane				2.3	dBm	
Average Launch Power of Off Transmitter Per Lane	T_{off}			-30	dBm	
Extinction Ratio	ER	2.5			dB	
Transmitter Transition Time	T_r			17	ps	
RIN_{14OMA}	RIN			-132	dB/Hz	
Optical Return Loss Tolerance	ORLT			14	dB	
Encircled Flux		>=86% at 19μm <=30% at 4.5μm				
Receiver						
Signaling Rate Per Lane (Range)		53.125 ± 100ppm			GBd	
Wavelength	λ_C	840		860	nm	
Damage Threshold Per Lane	AOP_D	5			dBm	
Average Receive Power Per Lane	AOP_R	-6.3		4	dBm	
Receive Power (OMA _{outer}) Per Lane	OMA _R			3.5	dBm	
Receiver Reflectance	RR			-15	dB	
Receiver Sensitivity (OMA _{outer})	TECQ < 1.4dB	SOMA		-4.4	dBm	
	1.4dB ≤ TECQ ≤ 3.4dB			-6.2+TECQ		
Stressed Receiver Sensitivity (OMA _{outer}) Per Lane	SRS			-1.8	dBm	2
Conditions of Stressed Receiver Sensitivity Test						
Stressed Eye Closure for PAM4 (SECQ) Per Lane Under Test	SECQ		4.4		dB	
OMA _{outer} of Each Aggressor Lane			3.5		dB	

Notes:

1. RMS spectral width is the standard deviation of the spectrum.
2. Measured with conformance test signal at TP3 for the BER = 2.4x10⁻⁴.

Pin Descriptions

Pin	Logic	Symbol	Name/Description	Notes
1		GND	Module Ground.	
2	CML-I	Tx2+	Transmitter Non-Inverted Data.	
3	CML-I	Tx2-	Transmitter Inverted Data.	
4		GND	Module Ground.	
5	CML-I	Tx4+	Transmitter Non-Inverted Data.	
6	CML-I	Tx4-	Transmitter Inverted Data.	
7		GND	Module Ground.	
8	CML-I	Tx6+	Transmitter Non-Inverted Data.	
9	CML-I	Tx6-	Transmitter Inverted Data.	
10		GND	Module Ground.	
11	CML-I	Tx8+	Transmitter Non-Inverted Data.	
12	CML-I	Tx8-	Transmitter Inverted Data.	
13		GND	Module Ground.	
14	LVC MOS-I/O	SCL	2-Wire Serial Interface Clock.	
15		Vcc	+3.3V Power Supply.	
16		Vcc	+3.3V Power Supply.	
17	Multi-Level	LPWn/PRSn	Low-Power Mode/Module Present.	
18		GND	Module Ground.	
19	CML-O	Rx7-	Receiver Inverted Data.	
20	CML-O	Rx7+	Receiver Non-Inverted Data.	
21		GND	Module Ground.	
22	CML-O	Rx5-	Receiver Inverted Data.	
23	CML-O	Rx5+	Receiver Non-Inverted Data.	
24		GND	Module Ground.	
25	CML-O	Rx3-	Receiver Inverted Data.	
26	CML-O	Rx3+	Receiver Non-Inverted Data.	
27		GND	Module Ground.	
28	CML-O	Rx1-	Receiver Inverted Data.	
29	CML-O	Rx1+	Receiver Non-Inverted Data.	
30		GND	Module Ground.	
31		GND	Module Ground.	
32	CML-O	Rx2+	Receiver Non-Inverted Data.	
33	CML-O	Rx2-	Receiver Inverted Data.	
34		GND	Module Ground.	
35	CML-O	Rx4+	Receiver Non-Inverted Data.	
36	CML-O	Rx4-	Receiver Inverted Data.	

37		GND	Module Ground.	
38	CML-O	Rx6+	Receiver Non-Inverted Data.	
39	CML-O	Rx6-	Receiver Inverted Data.	
40		GND	Module Ground.	
41	CML-O	Rx8+	Receiver Non-Inverted Data.	
42	CML-O	Rx8-	Receiver Inverted Data.	
43		GND	Module Ground.	
44	Multi-Level	INT/RSTn	Module Input/Module Reset.	
45		Vcc	+3.3V Power Supply.	
46		Vcc	+3.3V Power Supply.	
47	LVC MOS-I/O	SDA	2-Wire Serial Interface Data.	
48		GND	Module Ground.	
49	CML-I	Tx7-	Transmitter Inverted Data.	
50	CML-I	Tx7+	Transmitter Non-Inverted Data.	
51		GND	Module Ground.	
52	CML-I	Tx5-	Transmitter Inverted Data.	
53	CML-I	Tx5+	Transmitter Non-Inverted Data.	
54		GND	Module Ground.	
55	CML-I	Tx3-	Transmitter Inverted Data.	
56	CML-I	Tx3+	Transmitter Non-Inverted Data.	
57		GND	Module Ground.	
58	CML-I	Tx1-	Transmitter Inverted Data.	
59	CML-I	Tx1+	Transmitter Non-Inverted Data.	
60		GND	Module Ground.	

Electrical Pad Layout

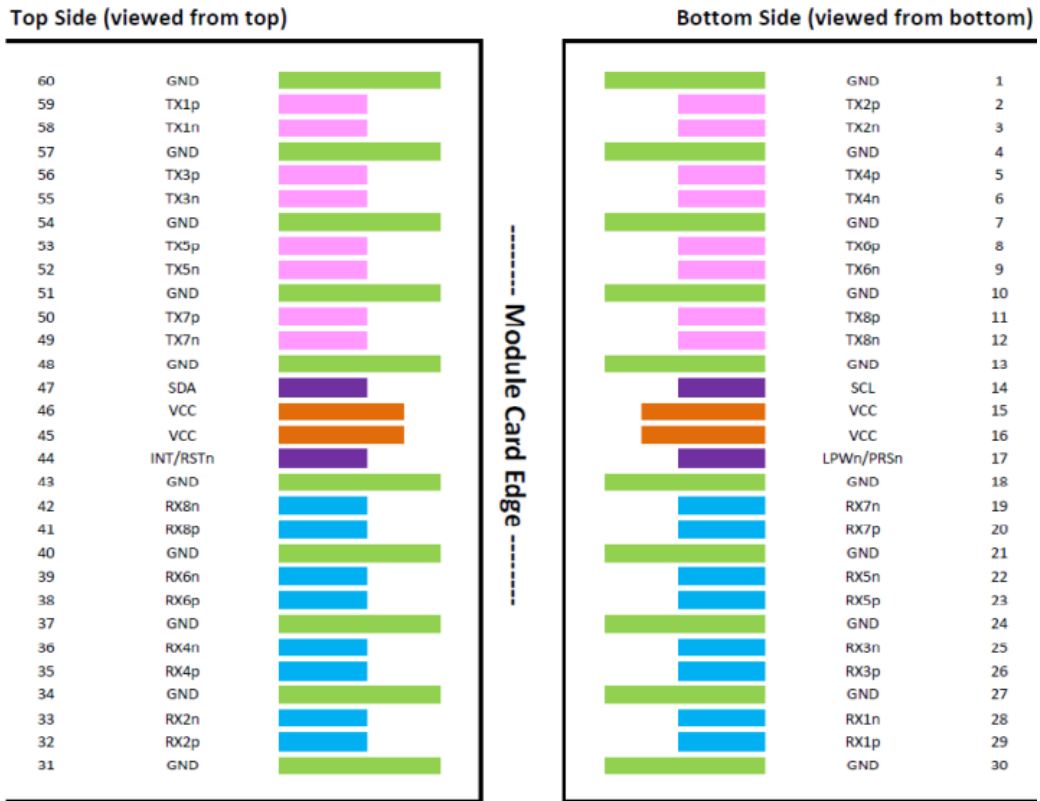

Recommended OSFP Host Board Schematic

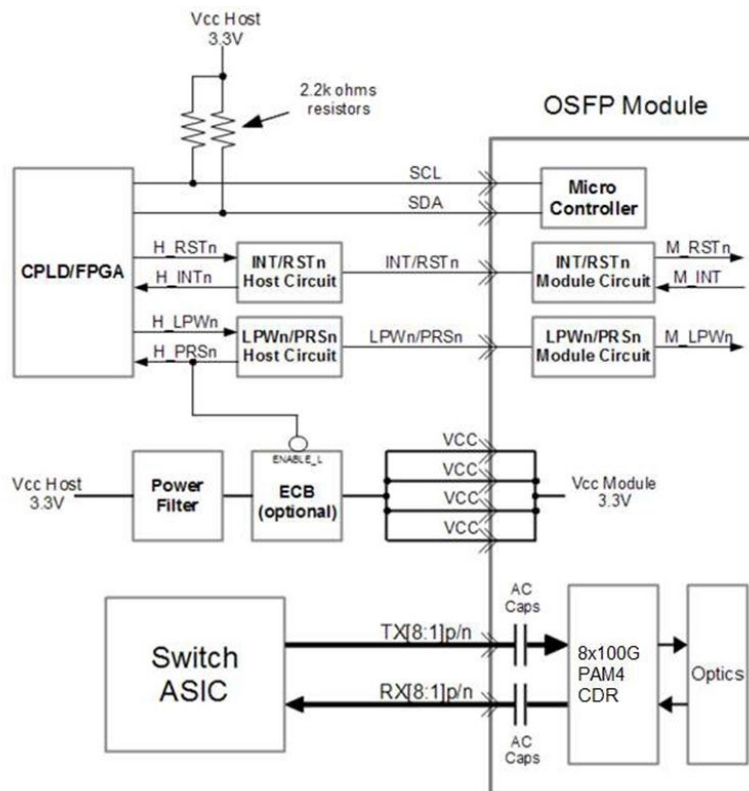

Mechanical Specifications

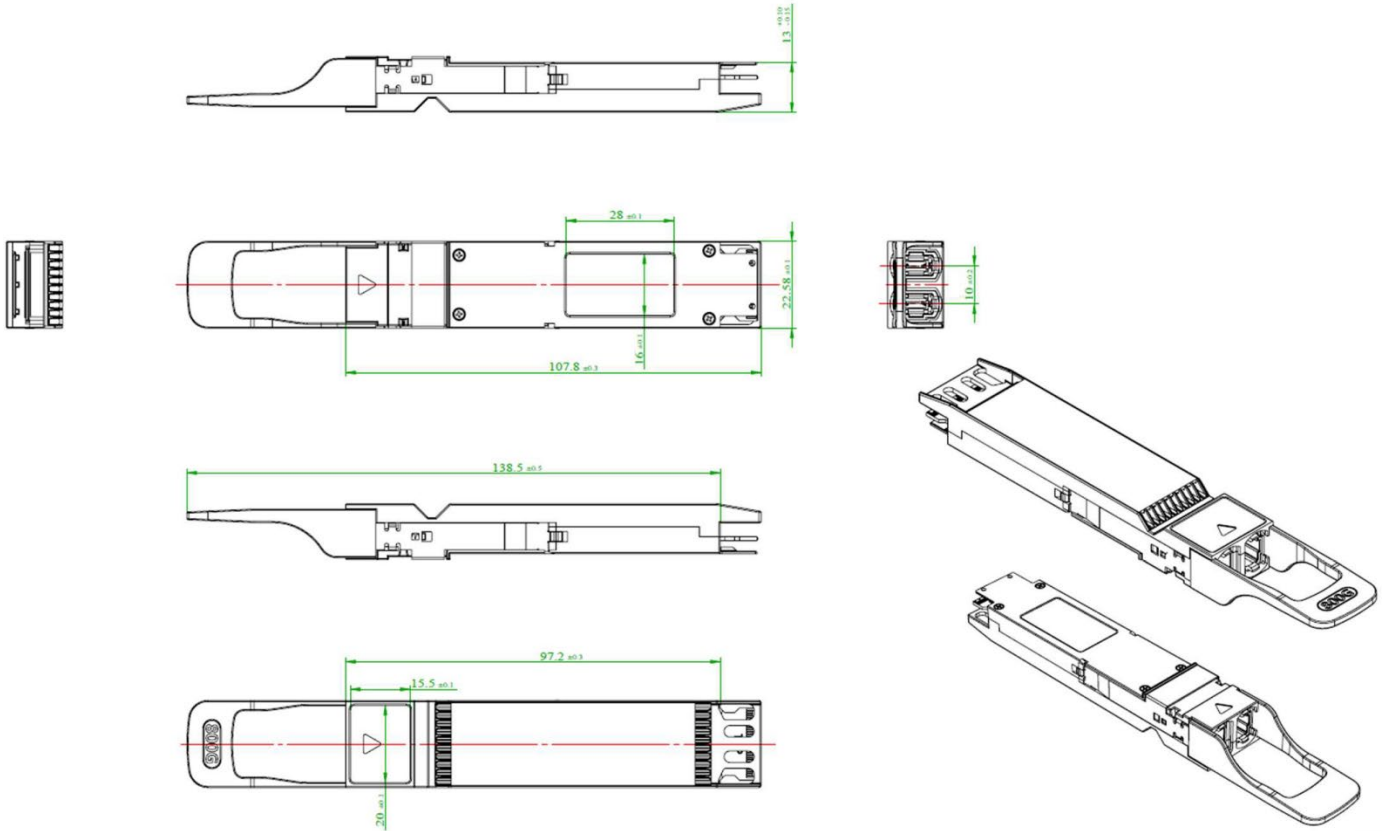

About ProLabs

Our extensive experience comes as standard. For over 20 years ProLabs has delivered optical connectivity solutions that give our customers freedom and choice through our ability to provide seamless interoperability. At the heart of our company is the ability to provide state-of-the-art optical transport and connectivity solutions that are compatible with more than 100 optical switching and transport platforms.

A Complete Portfolio of Network Solutions

ProLabs is focused on innovations in optical transport and connectivity. The combination of our knowledge of optics and networking equipment enables ProLabs to be your single source for optical transport and connectivity solutions from 100Mb to 1.6T while providing innovative solutions that increase network efficiency. We provide the optical connectivity expertise that is compatible with and enhances your switching and transport equipment.

The Trusted Partner

Customer service is our number one value. ProLabs has invested in people, labs and manufacturing capacity to ensure compatible products, and immediate answers to your questions. With Engineering and Manufacturing offices in the U.K. and U.S. augmented by field offices throughout the U.S., U.K. and Asia, ProLabs is able to be our customers best advocate 24 hours a day.



Contact Information

ProLabs US

Email: sales@prolabs.com

Telephone: 952-852-0252

ProLabs UK

Email: salessupport@prolabs.com

Telephone: +44 1285 719 600