

## MMA1T00-VS-C

Mellanox® MMA1T00-VS Compatible 200GBase-SR4 QSFP56 Transceiver (MMF, 850nm, 100m, MPO, DOM)

### Features:

- Supports SFF-8636 management interface
- MPO Connector
- Multi-mode Fiber
- Commercial Temperature 0 to 70 Celsius
- Hot Pluggable
- Metal with Lower EMI
- Excellent ESD Protection
- RoHS Compliant and Lead-Free

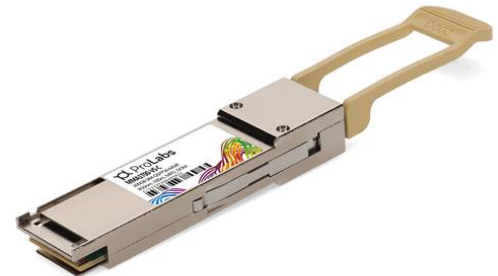

### Applications:

- 200GBase
- Ethernet
- Access and Enterprise

### Product Description

This Mellanox® MMA1T00-VS compatible QSFP56 transceiver provides 200GBase-SR4 Fibre Channel throughput up to 100m over multi-mode fiber (MMF) using a wavelength of 850nm via an MPO connector. It is guaranteed to be 100% compatible with the equivalent Mellanox® transceiver. This easy to install, hot swappable transceiver has been programmed, uniquely serialized and data-traffic and application tested to ensure that it will initialize and perform identically. Digital optical monitoring (DOM) support is also present to allow access to real-time operating parameters. This transceiver is Trade Agreements Act (TAA) compliant. We stand behind the quality of our products and proudly offer a limited lifetime warranty.

ProLabs' transceivers are RoHS compliant and lead-free.

TAA refers to the Trade Agreements Act (19 U.S.C. & 2501-2581), which is intended to foster fair and open international trade. TAA requires that the U.S. Government may acquire only "U.S.-made or designated country end products."



## Absolute Maximum Ratings

Parameter	Symbol	Min.	Typ.	Max.	Unit	Notes
Maximum Supply Voltage	V <sub>cc</sub>	0		3.63	V	
Storage Temperature	T <sub>stg</sub>	-40		85	°C	
Relative Humidity	RH	5		85	%	1
Operating Case Temperature	T <sub>c</sub>	0		70	°C	
Bit Error Ratio	BER			2.4E-4		2

### Notes:

1. Non-condensing.
2. The typical BER is better than 1E-6 when measured with a transmitter to produce SECCQ up to 3dB.

## Electrical Characteristics

Parameter	Symbol	Min.	Typ.	Max.	Unit	Notes
Module Supply Voltage	V <sub>cc</sub>	3.135	3.3	3.465	V	
Module Supply Current	I <sub>cc</sub>			1600	mA	
Module Power Dissipation	P <sub>D</sub>			5	W	
<b>Transmitter</b>						
Differential Data Input Voltage Peak-to-Peak Swing	V <sub>IN,pp</sub>			900	mV	
<b>Receiver</b>						
Differential Data Output Voltage Peak-to-Peak Swing	V <sub>OUT,pp</sub>			900	mV	

## Optical Characteristics

Parameter	Symbol	Min.	Typ.	Max.	Unit	Notes
<b>Transmitter</b>						
Signaling Rate Per Lane	Rate		26.5625		GBd	
Modulation Format	MF		PAM4			
Signaling Speed Accuracy	SSA	-100		100	ppm	
Center Wavelength	$\lambda$		850		nm	
RMS Spectral Width	$\Delta\lambda$			0.6	nm	
Optical Return Loss Tolerance	ORLT			12	dB	
Average Optical Power	Pavg	-6.5		+4	dBm	
Extinction Ratio	ER	3			dB	
Optical Modulation Amplitude Per Lane	OMA	-4.5		+3	dBm	
Launch Power in OMA Outer Minus TDECQ Per Lane		-5.9			dBm	
Transmitter and Dispersion Eye Closure for PAM4 (TDECQ) Per Lane	TDECQ			4.5	dB	
TDECQ – 10*log <sub>10</sub> (Ceq) Per Lane				4.5	dB	
Relative Intensity Noise	RIN			-128	dB/Hz	
Transmitter Transition Time Per Lane				34	ps	
Laser Off Power				-30	dBm	
Encircled Flux	EF		≥86% at 19μm ≤ 30% at 4.5μm			
<b>Receiver</b>						
Signaling Rate Per Lane	Rate		26.5625		GBd	
Modulation Format	MF		PAM4			
Signaling Speed Accuracy	SSA	-100		+100	ppm	
Center Wavelength	$\lambda$		850		nm	
Average Receive Power Per Lane	Pavg	-8.4		+4	dBm	
Receive Power Per Lane OMA	Po			3	dBm	
Receiver Reflectance	RL			-12	dB	
Receiver Sensitivity OMA Per Lane	S			Max = (-6.5, SECQ-7.9)	dBm	1
Damage Threshold	THd	5			dBm	

### Notes:

1. Receiver sensitivity is informative and defined for a transmitter with a value of SECQ up to 4.5dB.

## Pin Descriptions

Pin	Symbol	Description	Notes
1	GND	Ground.	1
2	Tx2-	Transmitter Inverted Data Input.	
3	Tx2+	Transmitter Non-Inverted Data Input.	
4	GND	Ground.	1
5	Tx4-	Transmitter Inverted Data Input.	
6	Tx4+	Transmitter Non-Inverted Data Input.	
7	GND	Ground.	
8	ModSelL	Module Select.	
9	ResetL	Module Reset.	
10	VccRx	+3.3V Power Supply Receiver.	2
11	SCL	2-Wire Serial Interface Clock.	
12	SDA	2-Wire Serial Interface Data.	
13	GND	Ground.	
14	Rx3+	Receiver Non-Inverted Data Output.	
15	Rx3-	Receiver Inverted Data Output.	
16	GND	Ground.	1
17	Rx1+	Receiver Non-Inverted Data Output.	
18	Rx1-	Receiver Inverted Data Output.	1
19	GND	Ground.	1
20	GND	Ground.	
21	Rx2-	Receiver Inverted Data Output.	
22	Rx2+	Receiver Non-Inverted Data Output.	
23	GND	Ground.	
24	Rx4-	Receiver Inverted Data Output.	
25	Rx4+	Receiver Non-Inverted Data Output.	
26	GND	Ground.	1
27	ModPrsL	Module Present.	
28	IntL/RxLOSL	Interrupt. Optionally configurable as RxLOSL via the management interface (SFF-8636).	
29	VccTx	+3.3V Power Supply Transmitter.	2
30	Vcc1	+3.3V Power Supply.	2
31	LPMode/TxDis	Low-Power Mode. Optionally configurable as TxDis via the management interface (SFF-8636).	
32	GND	Ground.	1
33	Tx3+	Transmitter Non-Inverted Data Input.	
34	Tx3-	Transmitter Inverted Data Input.	
35	GND	Ground.	1
36	Tx1+	Transmitter Non-Inverted Data Input.	
37	Tx1-	Transmitter Inverted Data Input.	
38	GND	Ground.	1

**Notes:**

1. GND is the symbol for signal and supply (power) common for the module. All are common within the module and all module voltages are referenced to this potential unless otherwise noted. Connect these directly to the host board signal-common ground plane.
2. VccRx, Vcc1, and VccTx are applied concurrently and may be internally connected within the module in any combination.

**Block Diagram of Transceiver**

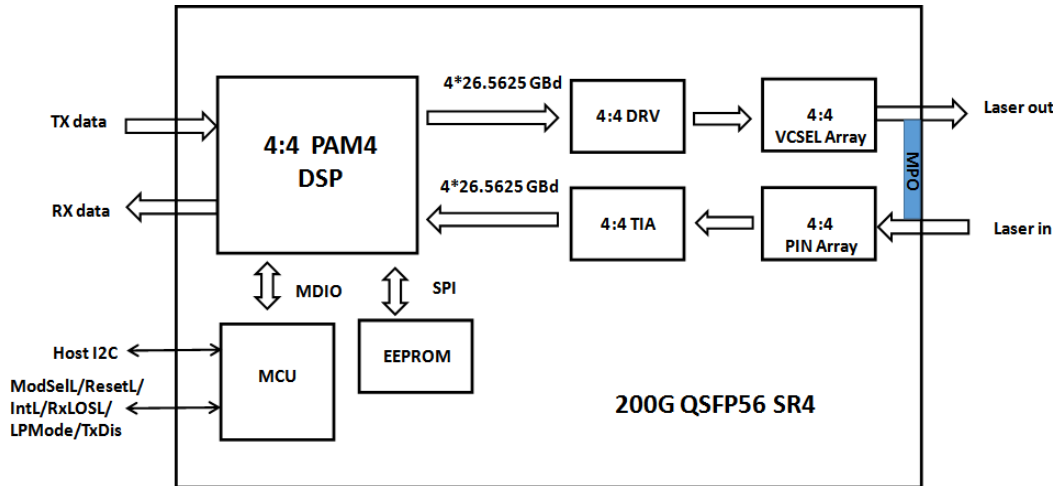

*Transmitter Section:* This module converts 4-channel 53.125Gbps electrical data to 4-channel 850nm 53.125Gbps optical signals for 212Gbps optical transmission.

*Receiver Section:* Similarly, this module optically converts 4-channel 850nm 53.125Gbps optical signals to 4-channel electrical data output on the receiver side.

## Recommended Interface Circuit

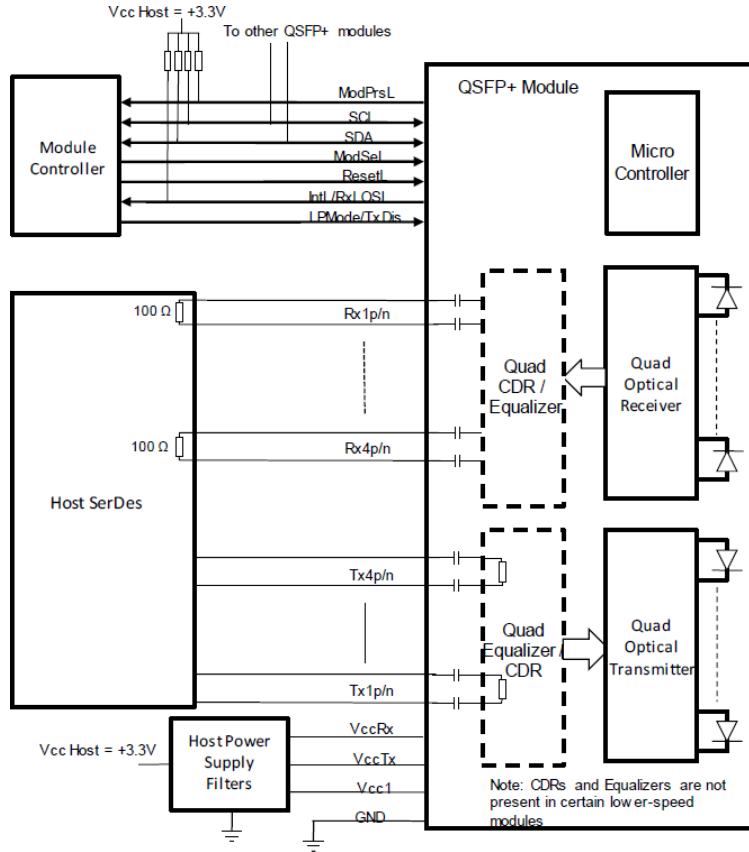

## Mechanical Specifications

Unit is millimeter. All dimensions are  $\pm 0.1\text{mm}$  unless otherwise specified.

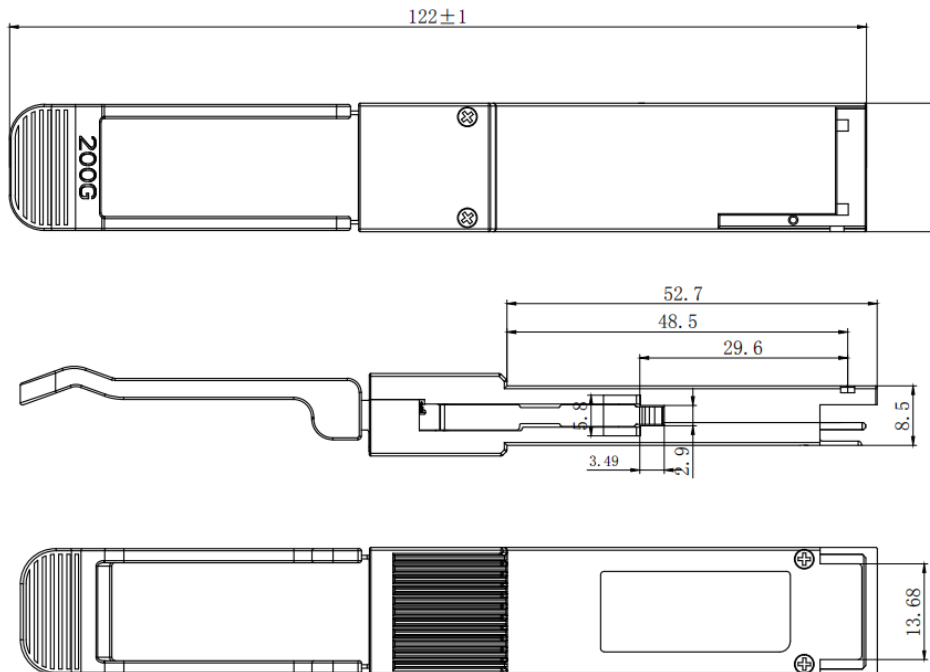

## About ProLabs

Our extensive experience comes as standard. For over 20 years ProLabs has delivered optical connectivity solutions that give our customers freedom and choice through our ability to provide seamless interoperability. At the heart of our company is the ability to provide state-of-the-art optical transport and connectivity solutions that are compatible with more than 100 optical switching and transport platforms.

## A Complete Portfolio of Network Solutions

ProLabs is focused on innovations in optical transport and connectivity. The combination of our knowledge of optics and networking equipment enables ProLabs to be your single source for optical transport and connectivity solutions from 100Mb to 1.6T while providing innovative solutions that increase network efficiency. We provide the optical connectivity expertise that is compatible with and enhances your switching and transport equipment.

## The Trusted Partner

Customer service is our number one value. ProLabs has invested in people, labs and manufacturing capacity to ensure compatible products, and immediate answers to your questions. With Engineering and Manufacturing offices in the U.K. and U.S. augmented by field offices throughout the U.S., U.K. and Asia, ProLabs is able to be our customers best advocate 24 hours a day.



## Contact Information

ProLabs US

Email: [sales@prolabs.com](mailto:sales@prolabs.com)

Telephone: 952-852-0252

ProLabs UK

Email: [salessupport@prolabs.com](mailto:salessupport@prolabs.com)

Telephone: +44 1285 719 600